

Varg Wellhead Design – Key Features

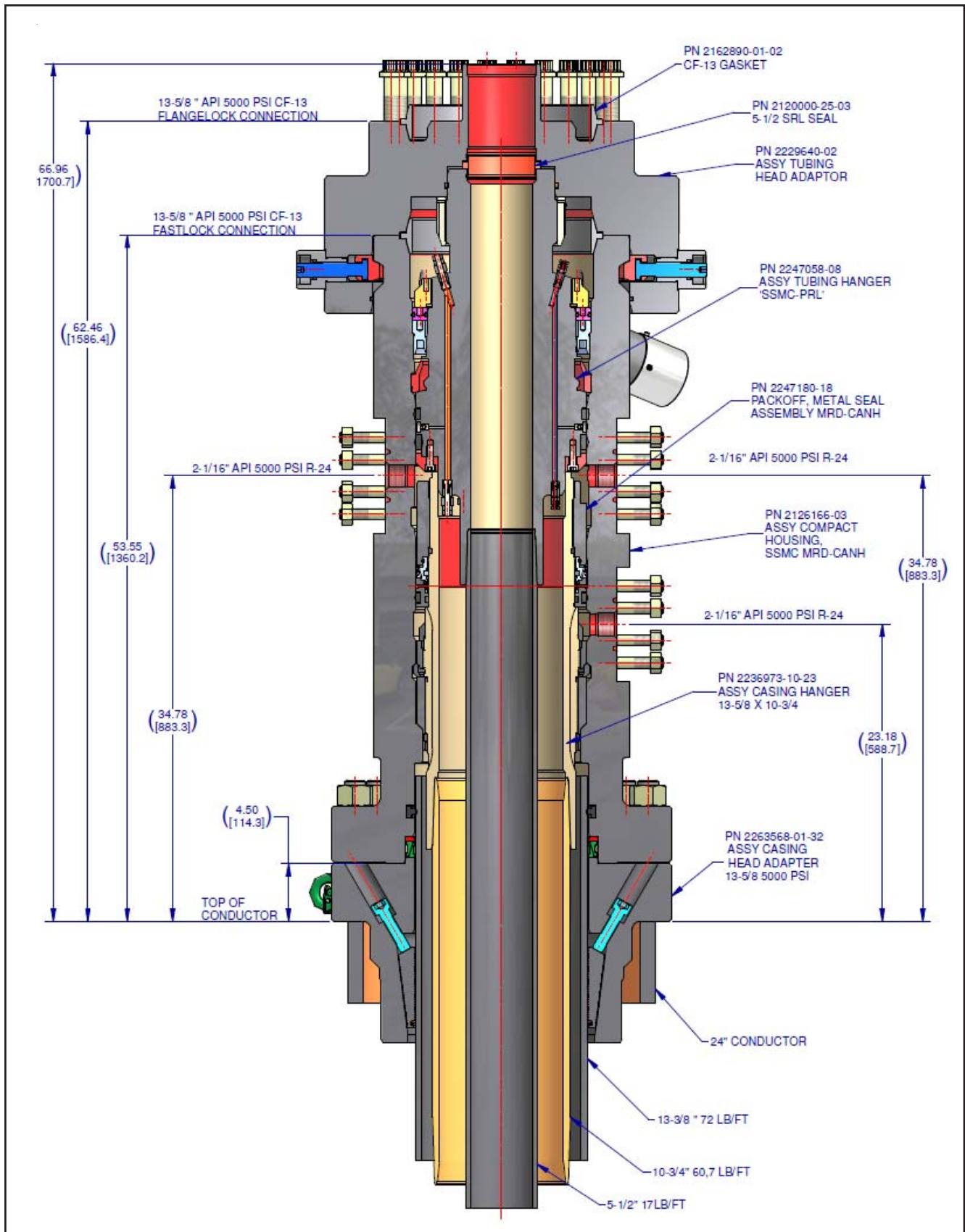

- 3 set installed successfully on Varg
- Quicker installation => less rig time
- Metal-to-Metal sealing in all annulus to meet Norsok D-010 table 33
- Designed for Gas Lift application
- 5000 psi (345 bar) pressure rating
- Wellhead Housing and Casing Hanger material class EE-NL
- Tubing Hanger material class HH-NL
- Temperature rating P-U
- Xmas Tree will be installed with 'Fastlock' for quick makeup and 360deg orientation
- 6 off control line penetrations in Tubing Hanger and Wellhead Housing
- Each cavity has 2 off test ports
- 4 off lifting eyes for offline installation/removal

System Drawing



RIGBOOK for TALISMAN VARG
 'SSMC' WELLHEAD EQUIPMENT, CASING PROGRAM:
 24" Conductor x 13-3/8" x 10-3/4" x 5-1/2"

RP-002655-03
 Rev 02
 Page 6

System Drawing SERVICE TOOLS

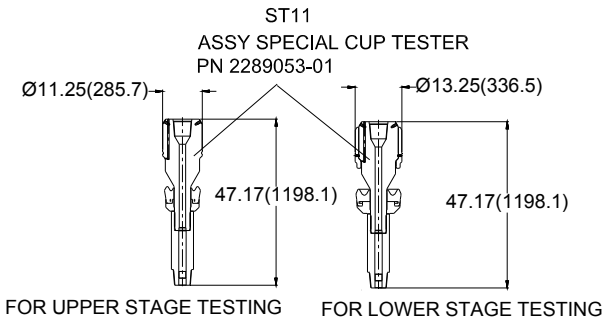
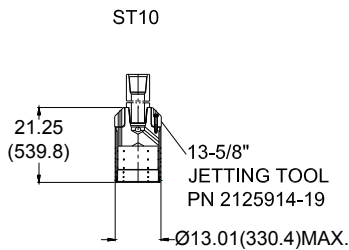
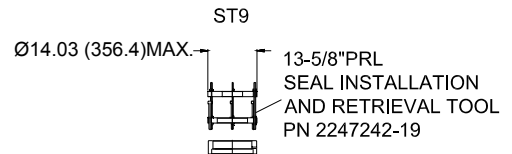
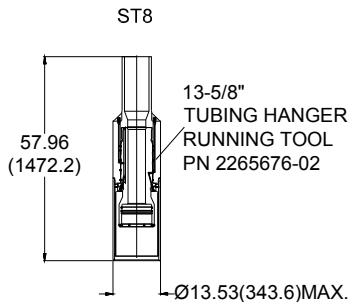
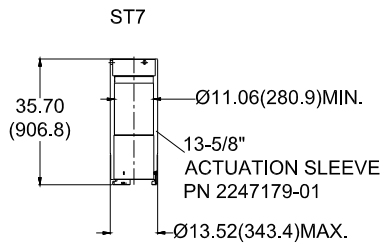
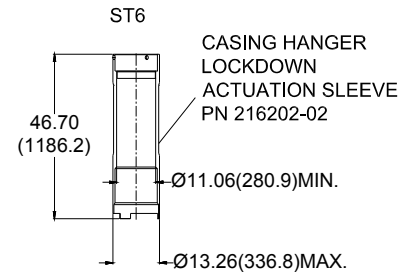
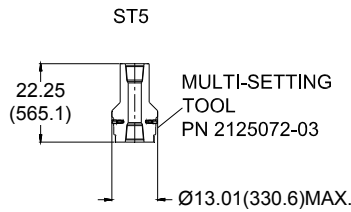
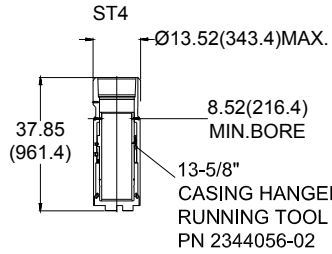
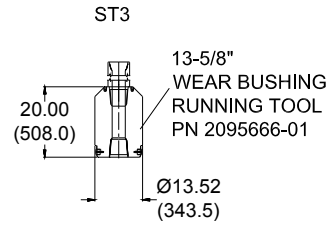
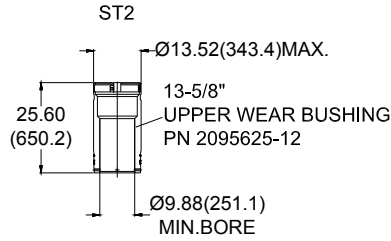
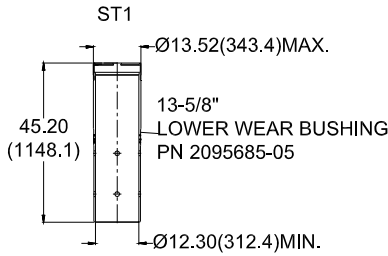

5-1/2" SRL
 SEAL INSTALLATION
 AND RETRIEVAL TOOL
 PN 2119760-25-01

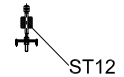

RP122001



RIGBOOK for TALISMAN VARG
 'SSMC' WELLHEAD EQUIPMENT, CASING PROGRAM:
 24" Conductor x 13-3/8" x 10-3/4" x 5-1/2"

RP-002655-03

Rev 02

Page 7

Bill of Materials

NOTE: Contact your Cameron representative for replacement part inquiries. Cameron personnel can check the latest revision of the assembly bill-of-material to obtain the appropriate and current replacement part number.

SECTION A ASSY SSMC WELLHEAD EQUIPMENT		SECTION A ASSY SSMC WELLHEAD EQUIPMENT	
Item.	Qty.	Description	Description
A1	1	ASSY, CASING HEAD ADAPTER, 13-5/8IN API 5K STUDDERED, W/ SUP PORT NECK, F/13-3/8IN OD CSG 'CANH' METAL SEAL TOP X13-3/8IN OD, SLIPLOCK CSG HANGER BOTTOM; API 6A 20th EDITION, MATERIAL CLASS: AA, BB, DD, EE-NL, TEMP RATING: P, S, T, U, V, PSL 3, PR 2 *** ACCORDING TO SP-005200-01 Part# 2263568-01-32	A3 1 ASSY, CASING HANGER MANDREL, TYPE 'SSMC MRD-CANH', 13-5/8IN X 10-3/4IN OD CSG 60.7 LB/FT VAM TOP THD. BTM. X 11.250IN OD 4TPI RH STUB ACME RUNNING THD TOP W/ THREADED LOAD SHOULDER SLEEVE, LOCKDOWN RING AND ENERGISING SLEEVE API 6A, 20TH EDITION, MATERIAL CLASS: AA, TEMPERATURE RATING: P+U, PSL 3, PR2 BODY MATERIAL: F22, 105K Part# 2236973-10-23
A2	1	ASSY, COMPACT SPOOL, TYPE SSMC MRD-CANH, TWO STAGES, 13-5/8IN NOM 5K FLANGE W/ CANH SEAL FOR 13-3/8IN OD CSG BTM PREP X 13-5/8IN 5K CF-13 FASTLOCK HUB TOP, W/TWO UPPER 2-1/16IN API 5K R-24 STUDDERED SIDE OUTLETS AND ONE LOWER 2-1/16IN API 5K R-24 STUDDERED SIDE OUTLET, W/ 1-1/2IN NOM VR THD, W/ SIX GRAYLOC #14 CONTROL LINE EXIT PORTS; API 6A 20TH ED, MATERIAL CLASS: AA, BB, DD, EE, TEMPERATURE RATING: P, S, T, U, V, PSL 3 OPTIONAL ITEMS ARE REQUIRED - SEE X-079100-01 F/ ORDERING INSTRUCTIONS W/ BLEEDER VALVE AND BRACKET PREP *** ACC TO SP-005200-01 Part# 2126166-03	A4 1 PACKOFF, METAL SEAL ASSEMBLY, MRD-CANH, 13-5/8" NOM. (13.30" RECESSED BORE). API 6A, PSL 3, PR2, T/CL: P-U; M/CL: EE-NL. Part# 2247180-18
			A5 1 ASSY SECTION, TUBING HANGER 13-5/8IN NOM. X 5-1/2IN 20.00 LB/FT VAM TOP BOX BTM; API 6A 20TH EDITION, PSL 3, MATERIAL CLASS HH-NL, TEMP CLASS P+U *** SP-005200-01 Part# 2247058-08
			A6 2 5-1/2" SRL METAL LIP SEAL RING 5.200 THRU BR, 5.440 SEAL BR, 6.053 HUB BR, 15,000 MAX WP (MAT'L ALLOY 718) Part# 2120000-25-03

Bill of Materials

NOTE :Contact your Cameron representative for replacement part inquiries. Cameron personnel can check the latest revision of the assembly bill-of-material to obtain the appropriate and current replacement part number.

SECTION A ASSY SSMC WELLHEAD EQUIPMENT	
Item.Qty.	Description
A7 1	ASSY, TUBING HEAD ADAPTOR, 13-5/8 NOM 5000 (CF-13) FASTLOCK CONNECTOR BTM X 13-5/8 NOM 5000 (CF-13) FLANGELOCK TOP W/5-1/2 'SRL' SEAL PREP BOTH ENDS. FULLY CLAD W/ALLOY 625. API 6A 20TH ED, TEMP CLASS P+U, MATLS CLASS HH-NL, PSL 3, PR 2. ***ACCORDING TO SP-005200-01 Part# 2229640-02
A8 2	GASKET, 13-5/8 CF-13S, 825 XYLAN COATED, FOR USE IN API 6A MATERIAL CLASS AA, BB, CC, DD-NL, EE-NL, FF-NL, HH-NL APPLICATIONS Part# 2162890-01-02
A9 1	NEEDLE VALVE, CONTROL LINE ISOLATION, 10000 PSI 4 BOLT FLANGE, U-14 GASKET, SINGLE NEEDLE VALVE 12500 PSI WP, 3/8" NPT OUTLET, 1/2" NPT INLET, 316 STAINLESS STEEL NACE, (BOLTS INCLUDED), PRODUCT MAY BE PURCHASED FROM THE FOLLOWING ENGINEERING APPROVED SUPPLIERS:- OLIVER VALVES LTD & KENMAC. Part# 2180894-06
A10 5	NEEDLE VALVE, CONTROL LINE ISOLATION, 10000 PSI 4 BOLT FLANGE, U-14 GASKET, SINGLE NEEDLE VALVE 12,500 PSI WP, 1/4 NPT OUTLET, 1/2 NPT INLET, 316 STAINLESS STEEL NACE, (BOLTS INCLUDED), PRODUCT MAY BE PURCHASED FROM THE FOLLOWING ENGINEERING APPROVED SUPPLIERS:- OLIVER VALVES LTD AND KENMAC. REF. OLIVER DWG NO. A8773. Part# 2180894-03

SECTION A ASSY SSMC WELLHEAD EQUIPMENT	
Item.Qty.	Description
A11 1	MALE CONNECTOR 3/8" TBG X 3/8" M NPT. INC 825 (SWAGELOK: 825-600-1-6) Part# 2742616-01
A12 2	ASSEMBLY; 'MS' TYPE CONTROL LINE FITTING FOR 3/8" OD TUBING (718 FITTING W/825 SEAL) Part# 2119942-01-04
A13 10	ASSEMBLY; 'MS' TYPE CONTROL LINE FITTING FOR 1/4" OD TUBING (718 FITTINGS W/ 825 SEAL) Part# 2119942-02-03
A14 5	UNION, PIPE, HEXAGON, STRAIGHT, 1/4" OD TUBE X 1/4" API MALE THREAD, SERIES MODIFIED, INCOLOY 825 MATERIAL. Part# 269046-02



RIG BOOK for TALISMAN VARG
 'SSMC' WELLHEAD EQUIPMENT, CASING PROGRAM:
 24" Conductor x 13-3/8" x 10-3/4" x 5-1/2"

RP-002655-03
Rev 02
 Page 9

ASSY 'SSMC' WELLHEAD AND XMAS TREE, CASING PROGRAM: 24" CONDUCTOR X 13-3/8" X 10-3/4" 5-1/2" TUBING

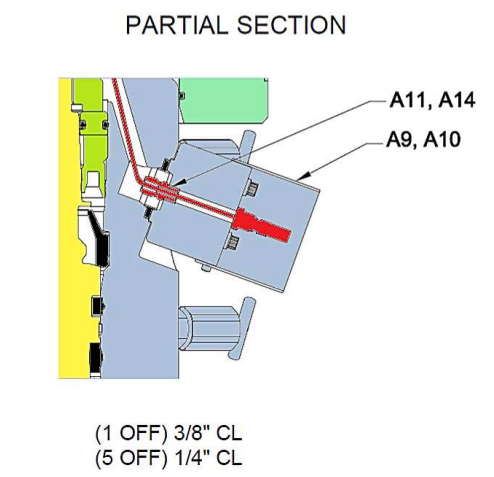
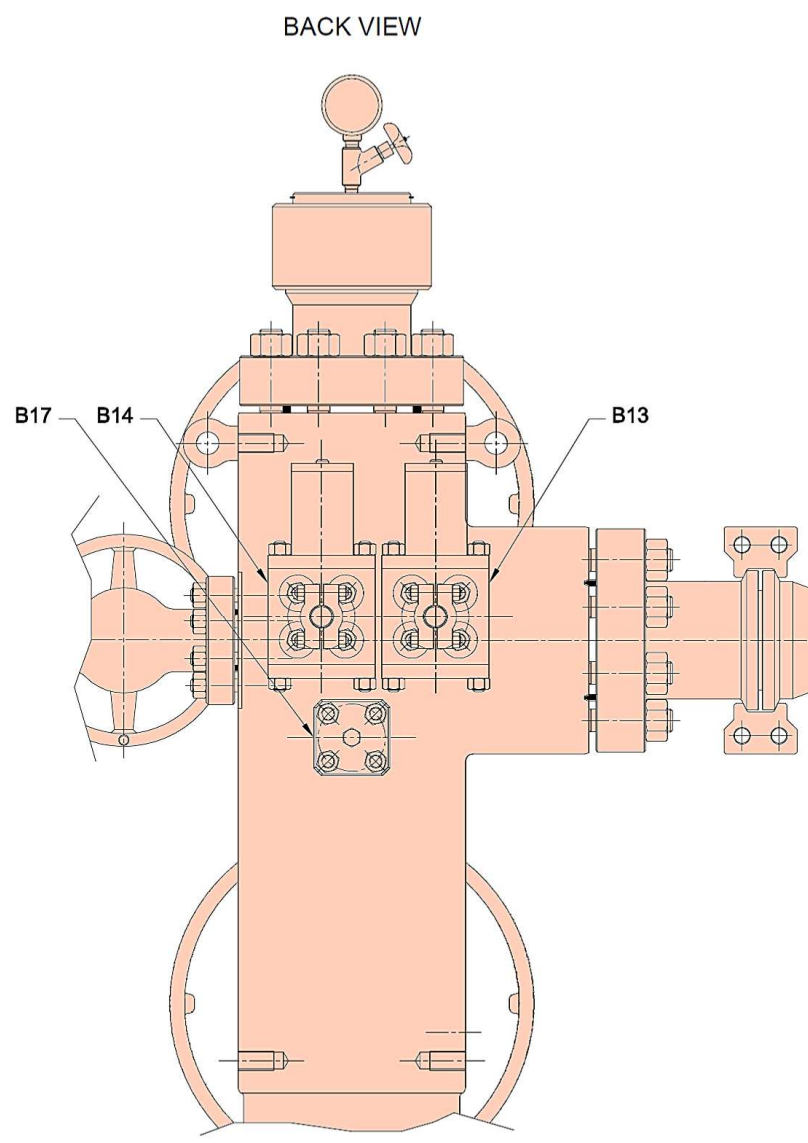
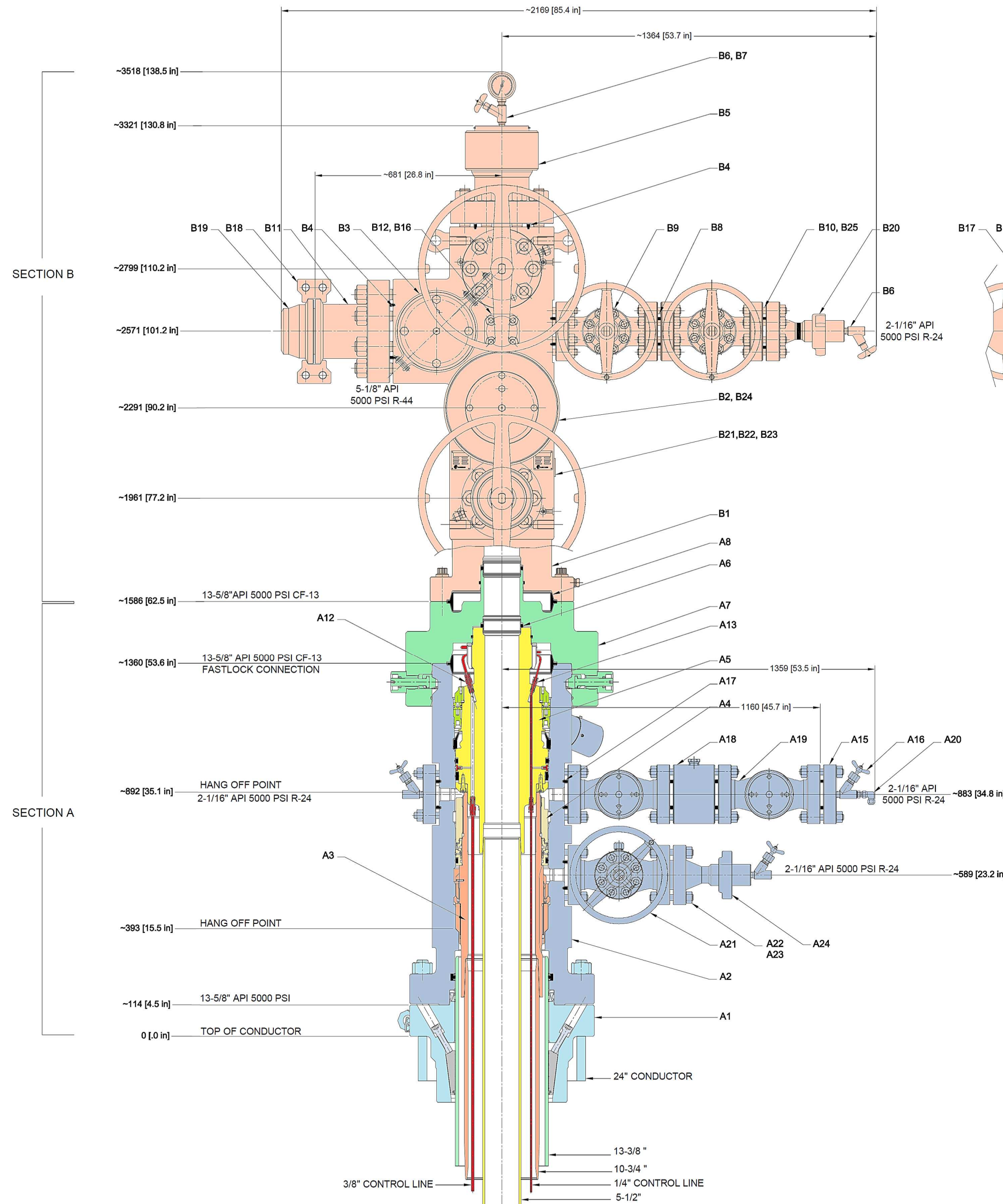

Item	Qty	Part Number	Description
ST12	1	2119760-25-01	5-1/2" SRL SEAL INST/RETR TOOL
ST11	1	2289053-01	ASSEMBLY, SPECIAL CUP TESTER
ST10	1	2125914-19	ASSY, JETTING TOOL, 13-5/8" NOM.
ST9	1	2247242-19	ASSY, 13-5/8 NOM PRL / SRL SEAL R/R TOOL
ST8	1	2265676-02	ASSEMBLY, TUBING HANGER RUNNING TOOL
ST7	1	2247179-01	ACTUATION SLEEVE, 13-5/8" NOM.
ST6	1	2161202-02	CASING HANGER LOCKDOWN ACTUATION SLEEVE
ST5	1	2125072-03	ASSEMBLY, MULTI-SETTING TOOL BODY
ST4	1	2344056-02	ASSY, CSG HGR COMB TL, 13-5/8, 10-3/4 VAM
ST3	1	2095666-01	ASSY, RUNNING TOOL, 13-5/8" NOM. WEAR BUSHING RUNNING TOOL
ST2	1	2095625-12	13-5/8" UPPER WEAR BUSHING
ST1	1	2095685-05	13-5/8" LOWER WEAR BUSHING

SECTION T: SERVICE TOOLS

B25	40	2709000-09-11	NUT, HVY HEX .875-9 2HM ZN PL
B24	1	2135991-01	WELDMENT, ACTUATOR SSV, STEM,
B23	4	705786	SCR # 4 X 0.250 18-8 DR RND HD TYPE U
B22	1	2013400-26	NAMEPLATE - BLANK
B21	1	2013400-25	NAMEPLATE FOR CHRISTMAS TREE
B20	1	2289616-02	ANSON (WECO) FLANGE AND UNION
B19	1	2731564-01	SEAL RING, GRAYLOC, SIZE 52
B18	1	2715344-01	CLAMP, GRAYLOC, SIZE 6, INCLUDING
B17	1	2265706-01	BODY, BLIND FLANGE, SPECIAL 4 BOLT
B16	1	2715576-01	ASSY, BLOCK NEEDLE VALVE, BX150,10K
B14	1	2341480-01	ASSEMBLY, HYDRAULIC NEEDLE VALVE
B13	1	2341479-01	ASSEMBLY, HYDRAULIC NEEDLE VALVE
B12	4	702003-15-05	RING GASKET, API BX-150 PSL 4
B11	1	2135595-03	ADAPTOR FLANGE, 5-1/8 API 5000 R-44
B10	16	702536-08-10-60	STUD, CONT THD .875-9 X 6.000
B9	2	141551-31-49-06	GV HWO FLS 02.06 05K FG PU HHNL 3G 2
B8	3	702002-02-45	RING GASKET, API RX-24 PSL 4
B7	1	007484-69	GAUGE, PRESSURE 10000 PSI 4.50 DIA
B6	2	007482-56	VALVE, NEEDLE 1/2 M/F NPT 10000 PSI
B5	1	2265120-01	ASSY, XMAS TREE CAP, 5-1/8 API
B4	2	702002-04-45	RING GASKET, API RX-44 PSL 4
B3	1	2135593-15	ACTUATOR, SURFACE, SSV, 5-1/8" 5K, FLS
B2	1	2135592-13	ACTUATOR, SURFACE, SSV, 5-1/8" 5K, TYPE 'FLS'
B1	1	2340737-01	ASSY, SSSBT, STYLE 'FF', TYPE 'FLS', 5/8" 5000 PSI

SECTION B: XMAS TREE ASSY, 'PRODUCTION', TYPE 'FF', PN: 2340738-01

A24	1	2715356	ANSON (WECO) FLANGE X UNION
A23	32	2709000-09-11	STUD SET, FULL THD., .875-9UNC-2
A22	16	702536-08-10-60	STUD SET, FULL THD., .875-9UNC-2
A21	1	162096-31-01-03	GV HWO FLS-TC 2.06 05K FG DD
A20	1	2135702-01	ASSY OF TWO FITTINGS CREATING
A19	2	2135603-02	ASSEMBLY, GATE VALVE, TYPE FLS,
A18	1	2135604-02	ASSEMBLY SPACER FLANGE, STUDDER,
A17	7	702002-02-44	RING GASKET, API RX-24 PSL 4 316 SST
A16	3	007482-56	VALVE, NEEDLE 1/2 M/F NPT 10000 PSI
A15	2	156494-02-05-03	BODY, FLANGE, BLIND 2-1/16 API 5000
A14	5	2742465-01	1/4" TUBING X 1/4" NPT PIPE CONNECTOR,
A13	10	2119942-02-03	ASSEMBLY; 'MS' TYPE CONTROL LINE
A12	2	2119942-01-04	ASSEMBLY; 'MS' TYPE CONTROL LINE
A11	1	2742616-01	MALE CONNECTOR 3/8" X 3/8" M NPT. INC 825
A10	5	2180894-03	NEEDLE VALVE, CONTROL LINE
A9	1	2180894-06	NEEDLE VALVE, CONTROL LINE
A8	2	2162890-01-02	GASKET CF-13S 825 / XYLAN
A7	1	2229640-02	ASSY, TUBING HEAD ADAPTOR, 13-5/8 NOM
A6	2	2120000-25-19	5-1/2" SRL METAL LIP SEAL RING
A5	1	2247058-08	ASSY SECT, TBG HGR, SSMCPRL, 13-5/8, HH, PU32
A4	1	2247180-18	PACKOFF, METAL SEAL ASSEMBLY, MRD-CANH
A3	1	2236973-10-23	ASSY, CSG HGR, SSMC, 13-5/8 X 10-3/4, AA, PU, 32
A2	1	2126166-03	ASSY, SSMC, SPL, 13-5/8 X 13-3/8 CSG, 5K, EE, PU3
A1	1	2263568-01-32	ASSY, CSG HD ADAPTER, 13-5/8, 5K, EE, PV, 32

SECTION A: ASSEMBLY SSMC WELLHEAD EQUIPMENT

ASSEMBLY WELLHEAD			
Item Cam.	Qty.	Part Number	Description